

Flash Programming

onTAP uses flexible, reusable models of flash devices to read FLASH data from Intel HEX formatted files and write the data to FLASH devices from scannable boundary scan pins. Serializing scan data at run-time, while programming, provides compact easily maintained models.

Time to Program

Programming times (PROG_TIME) will be determined by the relationship of the number of addresses (ADDRESSES) in the FLASH, the number of instructions, i.e., scans in the loop, the number of scan cells in the path (SHIFTS), and the effective clock throughput rate (CLOCK).

Please also be aware, in most applications, only *boot code* is programmed into a flash memory, and then the target application takes over from there.

See page 2, fig. 1.1 for a formula to calculate approximate programming time.

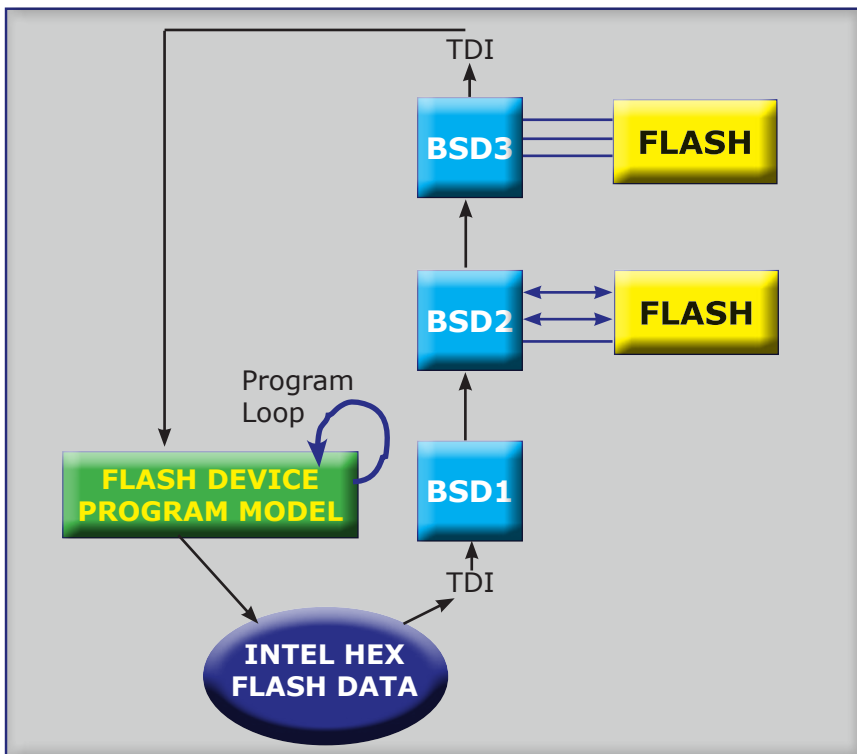

onTAP's Flash program models read data from HEX files, serialize it, and apply it to Flash devices through scannable pins on Boundary Scan devices.

Highlights: Flash Programming

- Program and verify FLASH devices
- Serializes and applies data from boundary scan pins.
- Reads INTEL HEX files to transfer data
- Employs high-level, C-like reusable, program models
- Runs with USB and standard programming cables from Xilinx, Altera, Lattice
- Up to 10 MHz clock rates through programming cables
- External control of Write Enable pins when accessible
- Virtual Pins automatically adapts FLASH pins in netlist circuit models to boundary scan pins

Sample Flash Program Models Available:

- Intel
28F128J3A150
- Atmel
AM29LV800B
- Atmel
AM29LV256
- Atmel
AM29LV160